

1 2 3 4 5 6 7 8



IF IN DOUBT ASK  
DO NOT SCALE

ABBREVIATIONS	
I	CURRENT INPUTS
BI	BINARY INPUTS
BO	BINARY OUTPUTS
CO	CHANGE OVER BINARY OUTPUT CONTACTS
NO	NORMALLY OPEN BINARY OUTPUT CONTACTS
NC	NORMALLY CLOSED BINARY OUTPUT CONTACTS

COMMUNICATIONS IDENTIFICATION	
COM1	RS485 (ON BLOCK 'B' TERMINALS 14,16,18 & 20)
COM2	USB TYPE 'B' PORT (ON RELAY FRONT LABEL)
COM3	FIBRE OPTIC (ON REAR COMMS MODULE)
COM4	FIBRE OPTIC (ON REAR COMMS MODULE)

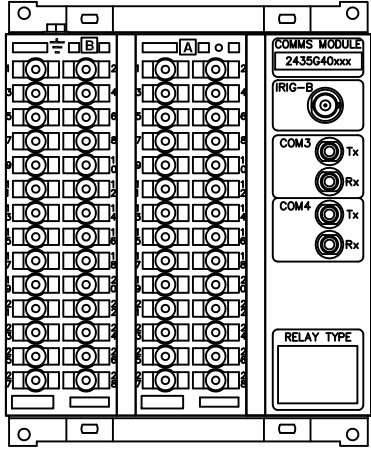

**NOTES**

- TERMINALS RECOMMENDED ARE PRE-INSULATED & MUST BE CRIMPED USING APPROVED TOOLING. AMP PIDG OR PLASTI GRIP FUNNEL ENTRY (RING TONGUE) FOR M4 FIXING STUD.  

SUPPLIER	PART NUMBER	CABLE SIZE
AMP	342103	0.25-1.6mm <sup>2</sup>
AMP	342143	1.0-2.6mm <sup>2</sup>

OR ANY OTHER MANUFACTURERS EQUIVALENT TERMINAL.
- FOR OUTLINE & PANEL DRILLING, SEE 2995X10006 (A4).
- CONNECTIONS TO THIS COMMUNICATIONS FACILITY IS BY SCREENED, TWISTED PAIR CABLE, ON SITE. WHEN WIRING OTHER FACILITIES ENSURE THAT THESE TERMINALS ARE NOT OBSCURED BY OTHER WIRE RUNS.
- CONTACTS SHOWN THUS ARE INTERNAL RELAY CASE ASSEMBLY AND CLOSE WHEN THE RELAY CHASSIS IS WITHDRAWN FROM THE CASE.

FOR INFORMATION ONLY  
UNCONTROLLED COPY  
NOT SUBJECT TO UPDATE

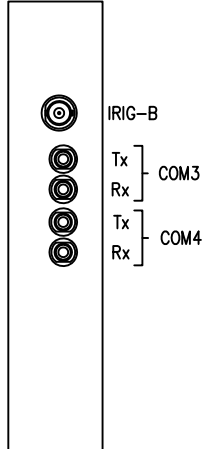
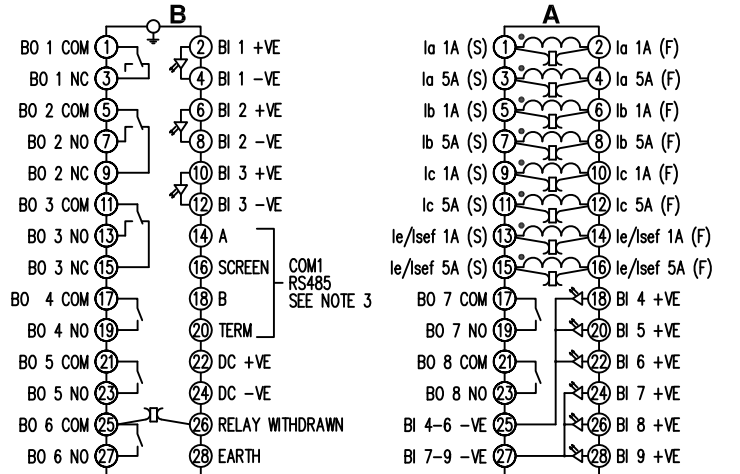

**MATERIAL:**

Dimensions in millimetres : Surface texture in micrometres.  
 Machine where marked ✓  
 For explanation of dimensions, tolerances, notes etc. see B.S.308.  
 Limit on untoleranced unmachined dimensions ± \_\_\_\_\_  
 Limits on untoleranced machined dimensions to B.S.4500;  
 i.e. up to 6±0.1; over 30 to 120±0.3; over 315±0.8;  
 over 6 to 30±0.2; over 120 to 315±0.5;  
 General unmachined angular tolerance ± \_\_\_\_\_

Finish: \_\_\_\_\_  
 Treatment: \_\_\_\_\_

Title:  
 TERMINAL ID & WIRING DIAGRAM FOR RM PLATFORM  
 (4I,9BI,2CO,5NO,1NC,RS485,2FO+IRIG-B) E6 CASE

**SIEMENS PROTECTION DEVICES LTD.**  
 Original Scale: NTS

First used on: \_\_\_\_\_  
 Similar Articles: \_\_\_\_\_  
 Supersedes: \_\_\_\_\_  
 Drg. No. 2435W40002

DRAWN M MATHER	CHECKED RDW	APPROVED RD.WATSON	DATE 19/03/07	IE	OPS	PCP	Purch.Spec. TQ	EAC	CE	STD	A3
----------------	-------------	--------------------	---------------	----	-----	-----	----------------	-----	----	-----	----

Copyright © 2007 Siemens Protection Devices Ltd. Hebburn

2 RDW	18/07/07	MN435/2886 RDW
1	19/02/07	CHANGE
ISSUE	DATE	NOTED